

RElift

MAKE THE DIFFERENCE

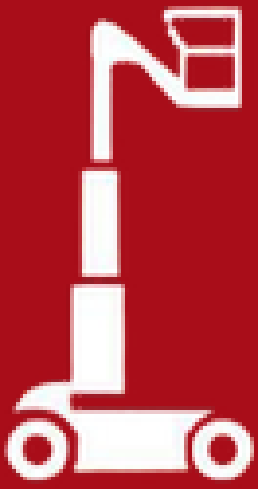

www.relift.in | Info@relift.in

BOOM LIFT

- **RE20AJ**
- **RE20AJLi**



STANDARD FEATURES

- Hydraulic leveling platform
- Mechanical release of driving brake
- Horn and buzzer safety warning
- Automotive grade full tube sheath protection
- Platform rotation
- Maximum tilt angle of 3 °
- Tilt alarm
- Over load sensor
- Flash light
- Emergency stop system
- Emergency brake release
- Environmentally friendly
- Zero emission
- Dual-Level Protection
- Electric drive
- Low-noise working environment
- 230 kg platform load capacity
- Multi-scenario flexibility
- Strong working range
- Easy operation in narrow spaces
- Diagnosis system
- Energy conservation
- Low maintenance
- Compact design

OPTIONS

- AC wiring to platform
- Non-marking Solid tires
- T-BOX (GPS)



TECHNICAL PARAMETERS

RE20AJ-20AJLi

Boom Lift

MODEL	RE20AJ-20AJ Li
TECHNICAL DATA	
Working height	20.4 m
Platform height	18.4 m
Outreach	11.3 m
Horizontal work amplitude	8.1 m
A Length (stowed)	8.35 m
B Width (stowed)	2.49 m
C Height (stowed)	2.48 m
D Wheelbase	2.5 m
Ground clearance	0.35 m
Platform size (L × W × H)	1.84 × 0.75 × 1.1 m
Total weight	9650 kg
PERFORMANCE	
Lift capacity	300 kg / 400 kg (restricted)
Turntable rotation	360° Continuous
Platform rotation	180°
Drive speed (stowed)	6.0 km/h
Drive speed (raised)	1.0 km/h
Gradeability (4WD)	40%
Turning radius (inside)	2.38 m
Turning radius (outside)	5.68 m
Turntable tail swing	0
Max. tilt angle (front/back – side/side)	5° / 3°
Drive / steering wheels number	4 × 2
Tyre specification / type	55/55D625 (foam-filled tyres)
POWER SOURCES	
Battery specification	DC 48 V / 445 Ah
Voltage	DC 24 V
Hydraulic tank capacity	60 L

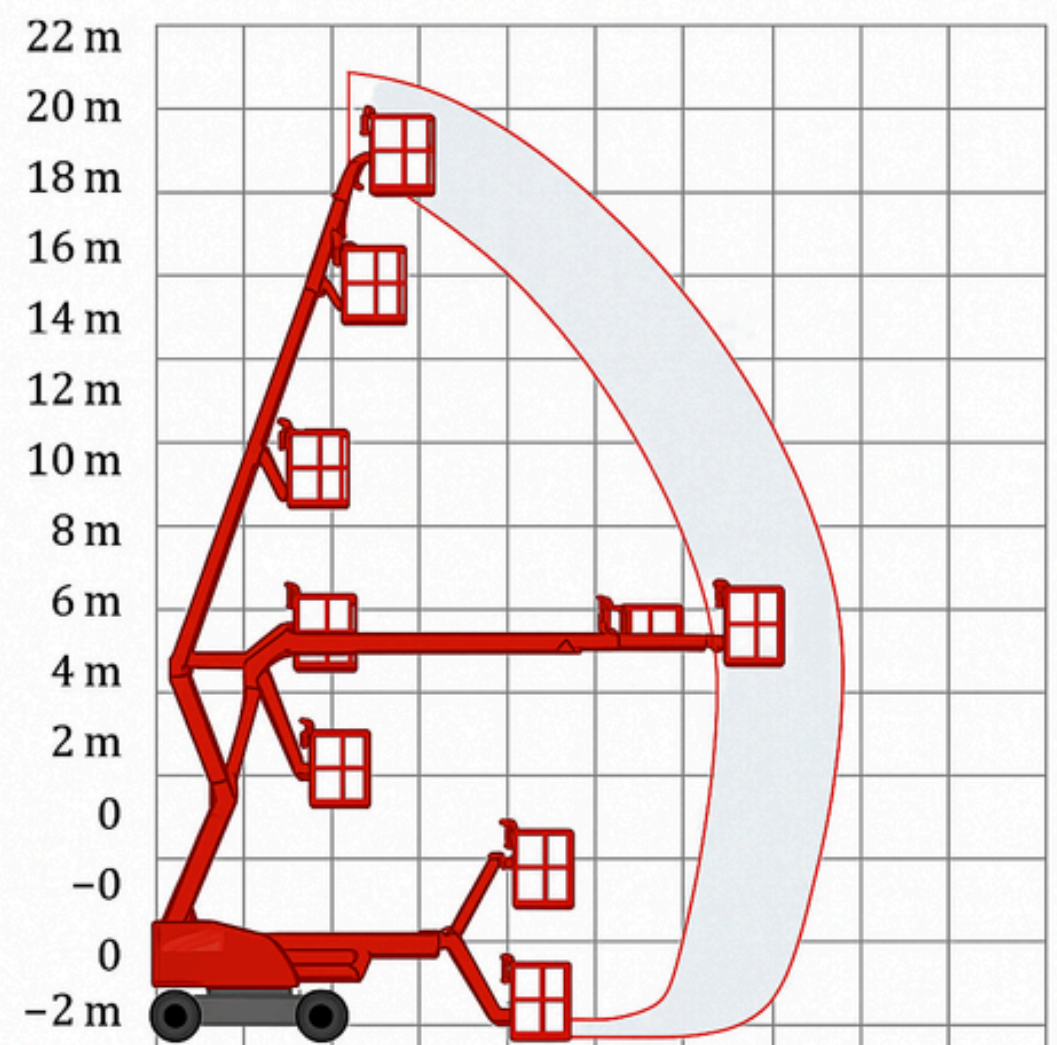
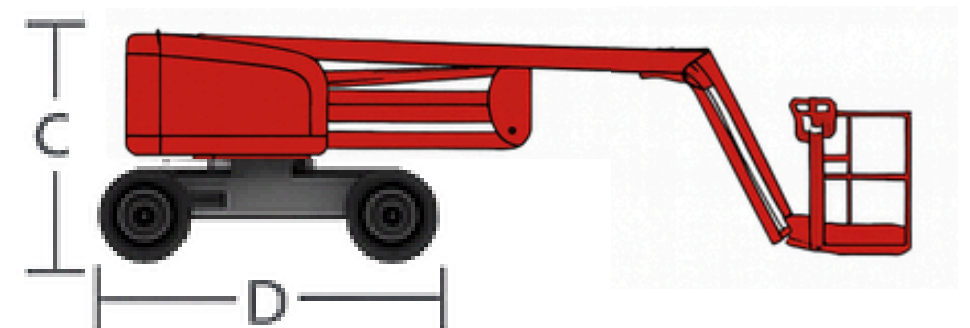
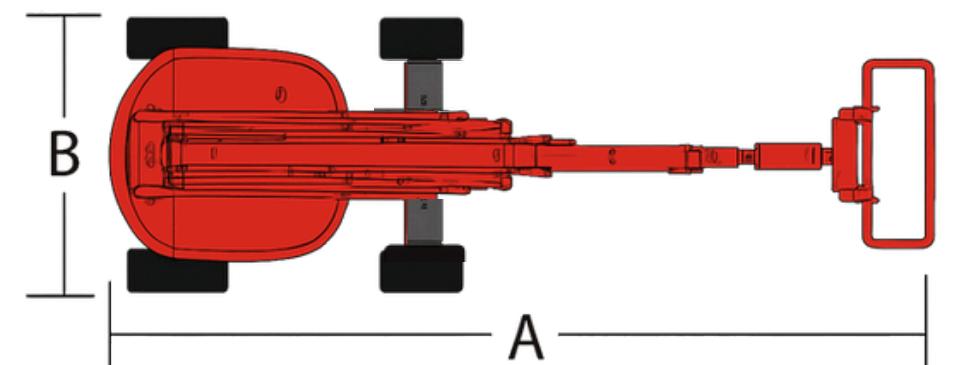

RElift

MAKE THE DIFFERENCE

HEADQUARTERS

Office No. 103, 104 Plan S Business Park, Plot no D 108/1, opp. D.Y.Patil Stadium, MIDC Industrial Area, Nerul, Navi Mumbai, Maharashtra 400705
Mobile : +91- 7456025602



MEMBER OF
APAO
Aerial Platform Association of India

www.relift.in | Info@relift.in